

ROMOLD ROAD GULLIES – AN OVERVIEW

TECHNICAL ADVANTAGES



- single piece unit
- integrated outlet spigot
- chemical resistant
- de-icing salt resistant
- for socket-ended pipe systems
- for welded pipe system
- settlement-free

only with the original:
no cast-in-place concrete in the rib area

to class D:
integrated load transfer,
no settlement of a building component

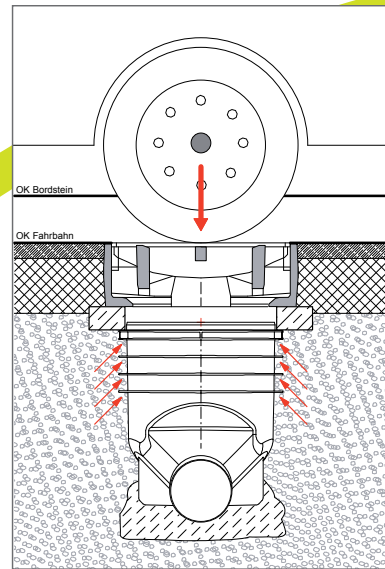
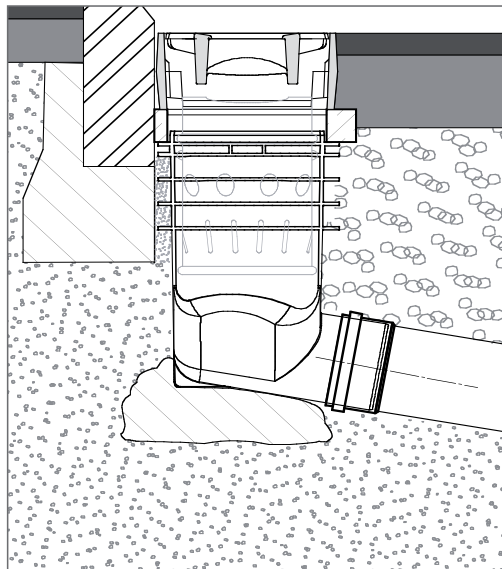

all ROMOLD
road gullies
can be drilled



all ROMOLD
road gullies
with height adjustment

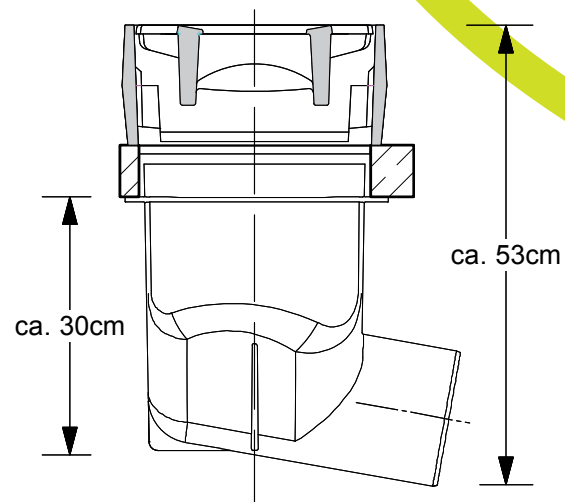

- easy to lift
- easy handling
- no lifting tool
- quick build-in

- commercial bearing rings
- commercial inlet rate
- swaging cover possible

