

PROJECT QUESTIONNAIRE

Romold GmbH
 Sägewerkstraße 5
 D-83416 Surheim
 Tel: +49-8654-4768-0
 Fax: +49-8654-4768-47
 E-mail: verkauf@romold.de

ROMOLD

edited: 10/2017

ROMOLD PE- cable chamber DN 800, water tight low model

order request for information

project: _____

chamber no.: _____

model: **KS 80.63/60**, height H 49-62cm

ROMOLD - system cover:
 class: PE- lid A15 B125 D400
please indicate

concrete load distribution ring
 for commercial, water tight cover system
 up to class D400

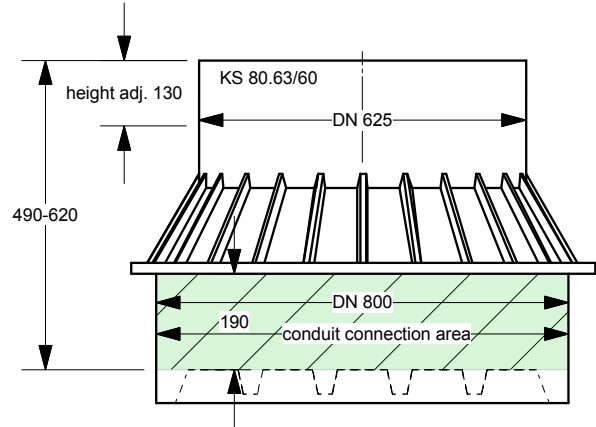

Conduit connection*) with each seal
 exclusively vertical to the chamber wall.

*) for informations regarding max. conduit connection see internet:
www.romold.de -> products -> electric and telekommunikations
 -> cable chambers model KS/FC

Please draw in the position and diameter
 of each conduit connection.

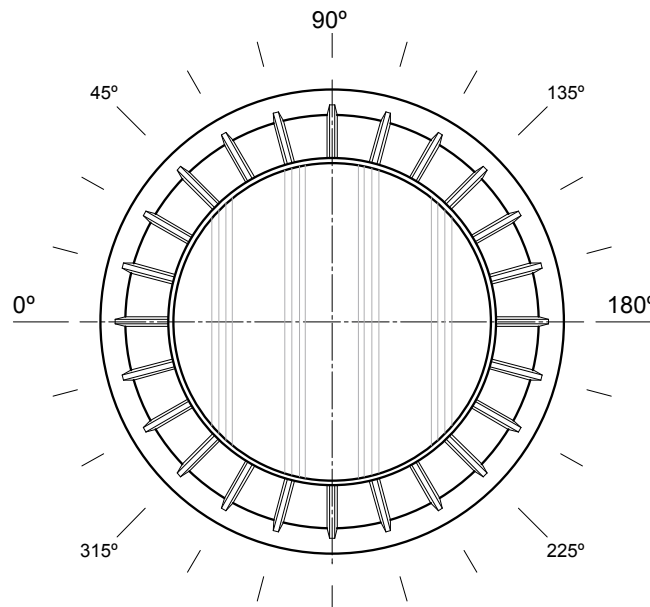

company: _____

contact person: _____

tel. / fax: _____

E-mail: _____

stamp

date, signature