

PROJECT QUESTIONNAIRE

Romold GmbH
 Sägewerkstraße 5
 D-83416 Surheim
 Tel: +49-8654-4768-0
 Fax: +49-8654-4768-47
 E-mail: verkauf@romold.de



ROMOLD - pressure pipe end chamber DN 625

order request for information

project: _____

manhole no.: _____

depth H [m]: _____
surface to channel

ground water level [m]: _____
ground water depth relative to surface

commercial cover
 class: B125 D400
please indicate

active carbon filter :
size and design after technical clarification

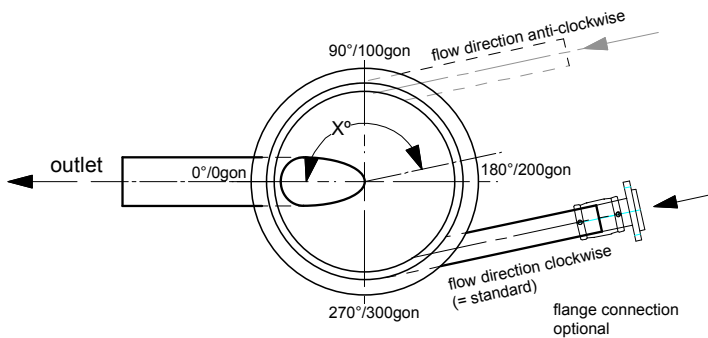
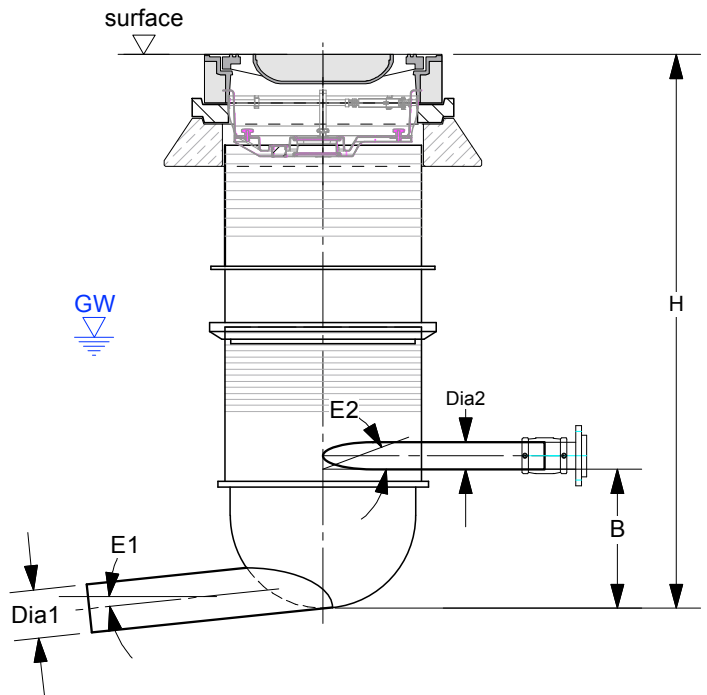

	DN/OD PVC, PP	PE Dia [mm] x e [mm]	others, clay pipe, concrete	bed drop B	horizontal angle [°]	pipe gradient E1, E2 [%]	water quantity [l/s] required information	special design, please check!	
								anti- clockwise	flange connection
outlet Dia 1				----	0°				
inlet Dia 2									
inlet Dia 3									

company: _____

contact person: _____

tel. / fax: _____

E-mail: _____

stamp

 date, signature